

Technical Data for Electro-hydraulic Thrusters ELDRO®

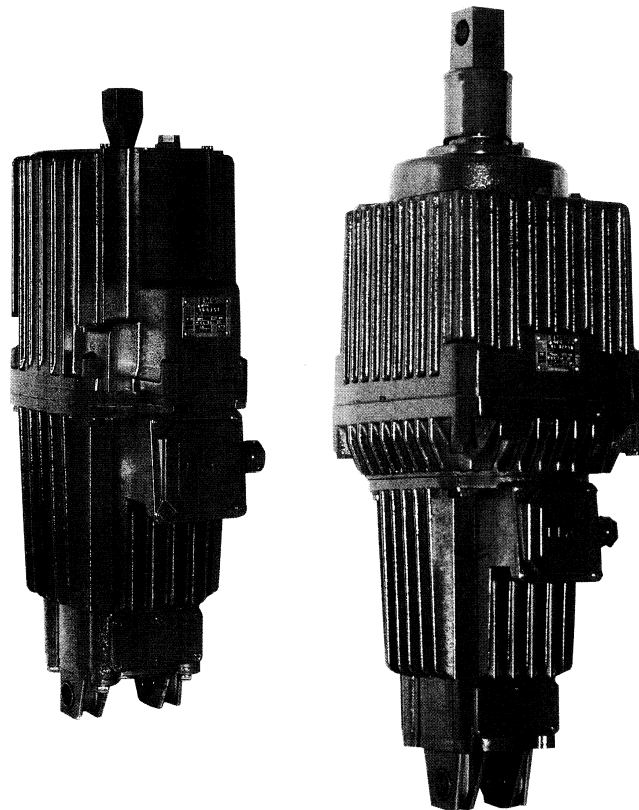

DC Version



CERTIFICATE
Quality Assurance System
DIN ISO 9001 / EN 29001
Registration No. 70100 M 504

Design and Method of Operation

Design

The basic components of the ELDRO Thruster, i. e. electric motor and closed hydraulic system are coaxially assembled to form a functional unit. The working fluid of the hydraulic system serves as the operating medium for the generation of thrust.

Method of Operation

In the switched-off state (de-energised), the hydraulic piston with the piston rod is at its lower limit.

In the switched-on state, the centrifugal pump delivers the working fluid under the piston and produces there hydraulic pressure, i. e. the thrust of the ELDRO unit. As a result of this pressure, the piston travels along its path against the internally fitted braking or re-setting spring or against an external load. The work resulting from the product of 'force x distance' is transmitted via the piston rod and the pressure lug to the device to be operated. Thus, the piston can either travel the total stroke distance or the externally reduced stroke lengths.

In accordance with the hydraulic transmission principle, at each end position of the piston, motor power consumption decreases relative to power intake for lifting action. Simultaneously the pressure within the thruster reaches its maximum value.

The driving motor is therefore less loaded when the piston is at rest. In that way the ELDRO Thruster becomes insensitive to mechanical overloads e. g. blocking of the brake. The result of all these factors is that electrical thermal protection is unnecessary.

When the thruster is in the disconnected state the piston returns to its original position under the impact of the external force (braking spring or weight).

Except for the starting and running down phases of the motor, the lifting and lowering speeds are linear. The response times obtained depend on the magnitude of the load as well as on the viscosity of the working fluid injected, which in turn is effected by the ambient temperature.

Characteristic Features

ELDRO Thrusters through their electrohydraulic mechanism, their suitability to integrate into brake systems and simple electrical commissioning procedure, offer for a wide range of applications the following advantages:

- High reliability.
- Long service life with minimum maintenance due to low wear operation under continuous self lubrication.
- Soft and smooth operation due to the hydraulic principle.
- Fast response (short regulating times).
- High switching frequencies.
- Simple installation and dismantling.
- No reversing contactors required as the motor may rotate in either direction.
- Overloading during operation not possible.
- Suitable for adjusting length of stroke from outside as required.
- Stepless prolongation of lifting and/or lowering times by the fitting of valves.

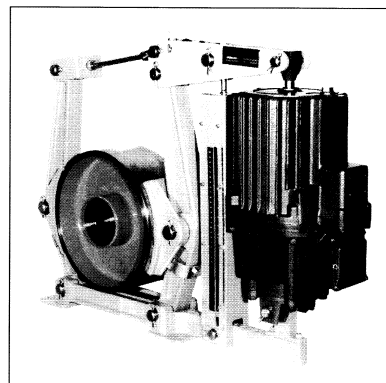

Double shoe brake with ELDRO Thruster Ed 80/6

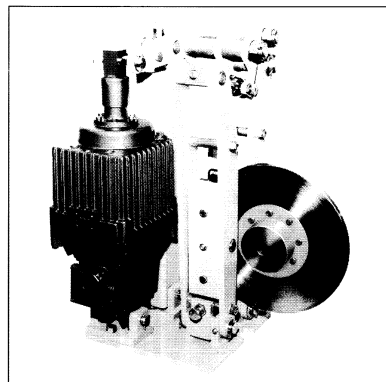

Disk brake with ELDRO Thruster Ed 301/6

ELDRO and Quality

- Certified quality assurance system to DIN ISO 9001
- 100% serial test including 16 hours endurance run and subsequent functional test with documentation of all technical data
- Acceptance certificate to DIN 50049
- Homologation of standard units in long-time test
- 12 months guarantee

Thruster Versions

Electrical Design

Motor

DC Shunt-wound motor construction according to DIN VDE 0530. For performance details refer to technical data. Insulation class F.

Modes of Operation

Continuous operation S1 and intermittent service S3-60% duty cycle. > 35°C ambient temperature technical data change – please enquire.

Voltages and Frequencies

Rated power up to formfactor 1.05
Standard voltage 220 V DC

Special windings 24 V – 500 V DC on request

AC versions, flameproof and explosion-proof design available.

Terminal Box

6-pole terminal board.
Connection screws M 4.
Protective conductor terminal M 4.
Earthing screw M 5 (outside on terminal box).

With special voltage < 100 V DC other connecting engineering.

Cable Gland

Cable gland Pg 21 for conductor sizes up to 4 x 2.5 mm² (Ø 17–19 mm).

Motor Circuit Breakers

When protecting the units by motor circuit breakers the thermal trigger should be set at least on 1.5 times the rated current for all types.

Mechanical Design

Assembly Dimensions

refer to dimension tables.

Mounting Positions

Vertical: piston rod uppermost.

Mounting Options except units with limit switches

The base mounting is 90° rotatable.

The top pressure lug is rotatable with all types.

Working Fluid

Hydraulic oil HL 10 acc. to DIN 51524, part 1, filled at factory.

Safety Measures

Double seal to oil chamber.
Dust proof double seal.
Piston rod chromium plated to size.
Piston rod tube to protect against the ingress of foreign bodies with types Eg 121, Eg 201, Eg 301.

Standard Paint

Synthetic resin lacquer varnish, impact and scratch resistant.
Coating thickness ~ 40 µm.
Tint RAL 7022 (umbergrey), other colours and coating 'Increased Protection against Corrosion' at extra charge.

Enclosure

IP 65 to EN 60529, DIN VDE 0470

Thruster Versions

Additional Equipment

Lifting or Lowering Valve (H, S, HS)

Built-in lifting (H) and/or lowering (S) valves for stepless prolongation of normal lifting or lowering times. The adjustable minimum values obtain a level 10-20 times the standard values.

Built-in valves in setting 'open' result in increased lifting and lowering times for short stroke units of approx. 0.1 to 0.2 seconds and for long stroke units of approx. 0.2 to 0.4 seconds. The valves are adjusted from the outside.

Braking Spring (c-Spring)

The c-spring generates the braking force. The specified force of the c-spring applies for $\frac{1}{3}$ of the piston rod's rated lift stroke or $\frac{2}{3}$ the rated lower stroke.

Re-setting Spring

Operation similar to c-spring, re-setting force is, however, lower (on request).

Increased Protection against Corrosion

Special paint: Polyurethane lacquer
 Primer: one coat
 Paintfinish: polyurethane varnish
 Coating thickness: $\sim 80 \mu\text{m}$
 Tint: RAL 7022 (umbergrey)

Limit Switches

For electrical indication of the release or closing positions of the brake, mechanical or inductive (contactless) limit switches can be fitted as standard. The appropriate types of switches are listed in the technical data sheet 'Limit Switches'.

All additional equipment is to be ordered separately at extra charge.

Key to Types

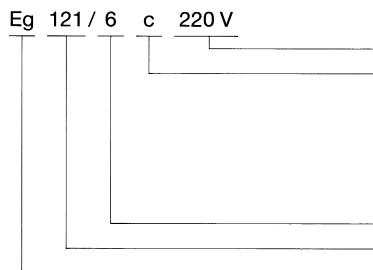

- Rated voltage
- Code for additional equipment
- c Braking spring (c-spring)
- H Lifting valve
- S Lowering valve
- E Limit switch, mechanical
- EB Limit switch, inductive
- Stroke in cm
- Lifting force x 10 in N
- Eg: ELDRO, DC version
- Ed: ELDRO, 3 ph AC version

Performance in Service depending on Ambient Temperatures

Temperature range	Hydraulic fluid	Performance in service
-15°C to +35°C	HL 10, DIN 51524, part 1	In the lower range of ambient temperatures the lifting times may increase up to four times the specified lifting times when the unit is operated the first time. The lowering times remain unaffected.
-35°C to +35°C	Special low temperature fluid	
more than +35°C	Special hydraulic fluid	request necessary

Characteristics

Technical Data

Type	Lifting force N	Stroke mm	Thrust N cm	Braking spring force (c-spring) ¹⁾ N	Lifting time sec.	Lowering time sec.	Power consumption ²⁾ W	Current consumption at 220 V DC ²⁾ A	Duty rating at S3-60% duty cycle ³⁾ c/h	Weight kg
Short-stroke units										
Eg 50/6	500	60	3000	460	0.4	0.5	350	1.6	1000	27
Eg 80/6	800	60	4800	750	0.5	0.4	330	1.5	1000	27
Eg 121/6	1250	60	7500	1200	0.6	0.5	330	1.5	1000	43
Eg 201/6	2000	60	12000	1900	0.7	0.4	430	2.0	1000	43
Eg 301/6	3000	60	18000	2700	0.8	0.4	470	2.2	800	43
Long-stroke units										
Eg 50/12	500	120	6000	—	0.5	0.8	350	1.6	600	31
Eg 80/12	800	120	9600	—	0.8	0.6	330	1.5	600	31
Eg 121/12	1250	120	15000	—	1.0	0.7	330	1.5	500	44
Eg 201/12	2000	120	24000	—	1.2	0.6	430	2.0	500	44
Eg 301/12	3000	120	36000	—	1.4	0.6	470	2.2	400	44

1) Values of braking force apply to 1/3 of the rated stroke.

2) Values at end-position of piston. During lifting operation the specified values multiply. In the lower range of temperature the current and power consumption increases.

3) Continuous operation S1 and intermittent service S3 are permitted up to +35° C ambient temperature.

All technical data are mean values related to operating temperature of unit with hydraulic fluid Shell Morlina 10.

Approximate calculation for current consumption for non-standard voltages:

$$I_x = \frac{U_{(220V)}}{U_{(x)}} \cdot I_{(220V)}$$

c-Spring-Diagrams

Parameter values in Newtons (N)

--- necessary force to compress c-spring
— force given from c-spring (braking force)

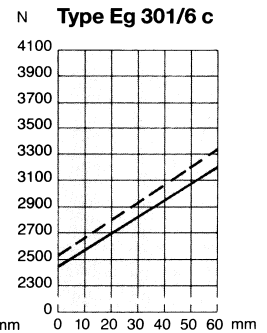
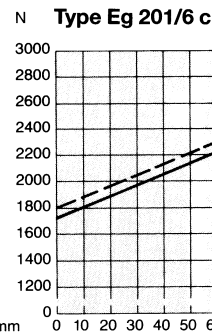
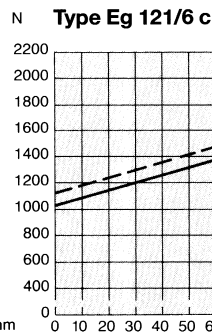
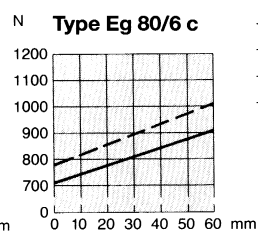
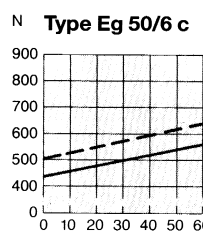

Dimension Drawings

Eg 50/6, Eg 80/6, Eg 50/12, Eg 80/12

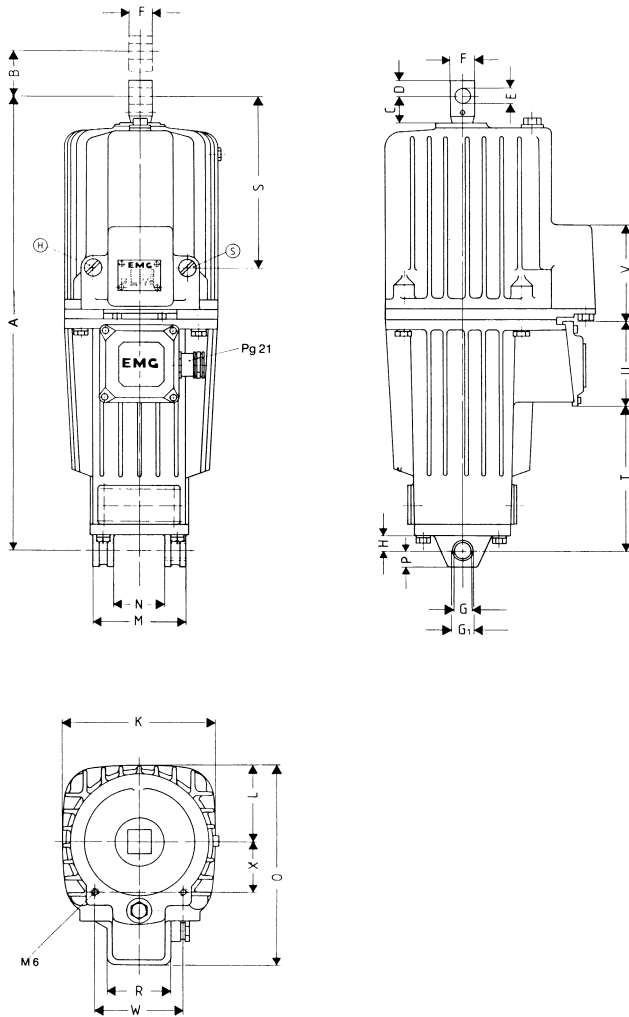

The motor housing with terminal box can be rotated in steps of 90° (indicate when ordering).
 Mounting options, except units with limit switches:
 The base mounting is bolted and 90° rotatable, the top pressure lug is rotatable.

Ⓜ = Lifting valve Ⓝ = Lowering valve

Dimension Table

Type	A	B	C	D	E ¹⁾	F	G ²⁾	G ²⁾	H	K	L	M	N	O	P	R	S	T	U	V	W	X
Eg 50/6	570	60	36	18	20	30	20	24	23	195	97	120	60	254	22	90	217	172	100	120	110	65
Eg 80/6	570	60	36	18	20	30	20	24	23	195	97	120	60	254	22	90	217	172	100	120	110	65
Eg 50/12	650	120	36	18	20	30	20	24	23	195	97	120	60	254	22	90	217	172	100	120	110	65
Eg 80/12	650	120	36	18	20	30	20	24	23	195	97	120	60	254	22	90	217	172	100	120	110	65

1) tolerance⁺0,1

2) tolerance⁺0,15

G changeable to G₁, by removing of the clamping bush

All dimensions in millimeters

Dimension Drawings

Eg 121/6, Eg 201/6, Eg 301/6, Eg 121/12, Eg 201/12, Eg 301/12

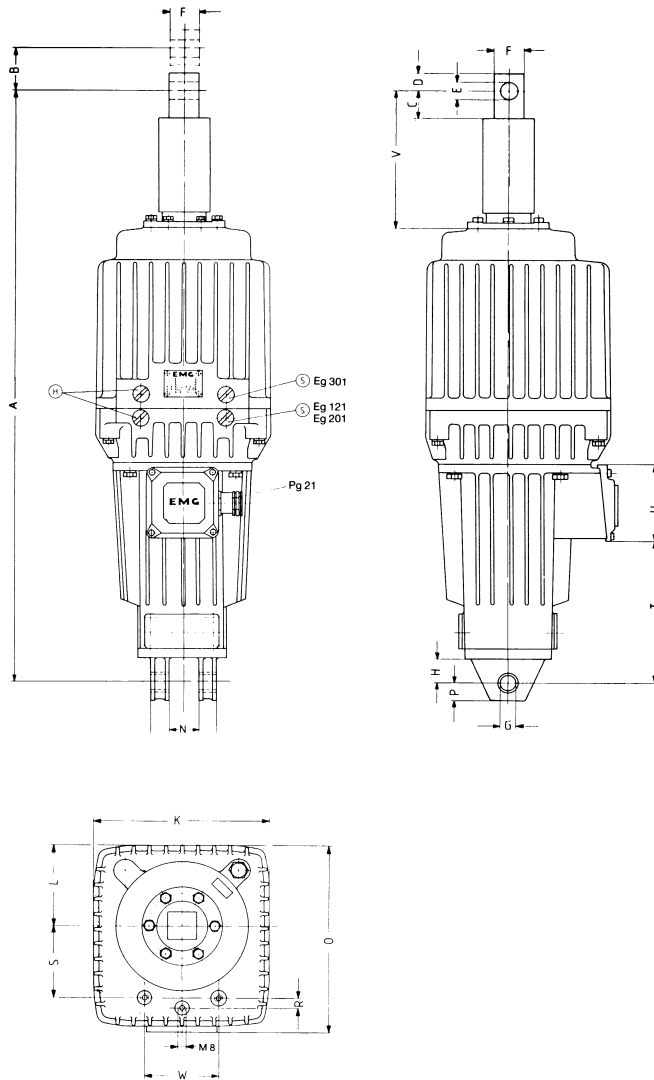

Lifting Marks

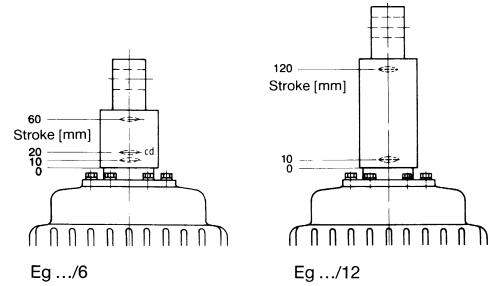

For easier setting and checking of the brake the piston guide bush of the thruster is marked. These marks can be read at the bottom edge of the piston rod protection tube (see drawing).

The motor housing with terminal box can be rotated in steps of 90° (indicate when ordering).
 Mounting options, except units with limit switches:
 The base mounting is bolted and 90° rotatable, the top pressure lug is rotatable.

(H) = Lifting valve (S) = Lowering valve

Dimension Table

Type	A	B	C	D	E ¹⁾	F	G ²⁾	H	K	L	M	N	O	P	R	S	T	U	V	W
Eg 121/6	765	60	38	25	25	40	25	35	240	112	90	40	260	25	15	100	172	100	130	100
Eg 201/6	765	60	38	25	25	40	25	35	240	112	90	40	260	25	15	100	172	100	130	100
Eg 301/6	765	60	38	25	25	40	25	35	240	112	90	40	260	25	15	100	172	100	130	100
Eg 121/12	825	120	38	25	25	40	25	35	240	112	90	40	260	25	15	100	172	100	130	100
Eg 201/12	825	120	38	25	25	40	25	35	240	112	90	40	260	25	15	100	172	100	130	100
Eg 301/12	825	120	38	25	25	40	25	35	240	112	90	40	260	25	15	100	172	100	130	100

1) tolerance: ^{-0.1} 2) tolerance: ^{+0.25}/_{+0.15}

All dimensions in millimeters

Other EMG products and system resolving

DREHMO® Electro-mechanical Actuators
Servo Technique / Strip guiding for the metals industry
Diesel rail car equipment

Your local representative:

Elektro-Mechanik GmbH
Industriestraße 1
D-57482 Wenden
Phone: (02762) 612-0
Telefax: (02762) 612-320
Internet: <http://www.emg-wenden.de>
eMail: V1@EMG-wenden.de