

Technical Data for Electro-hydraulic Thrusters ELDRO®

Ein Unternehmen
der Elexis-Gruppe

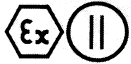

For using in underground mines



For using in hazardous atmospheres

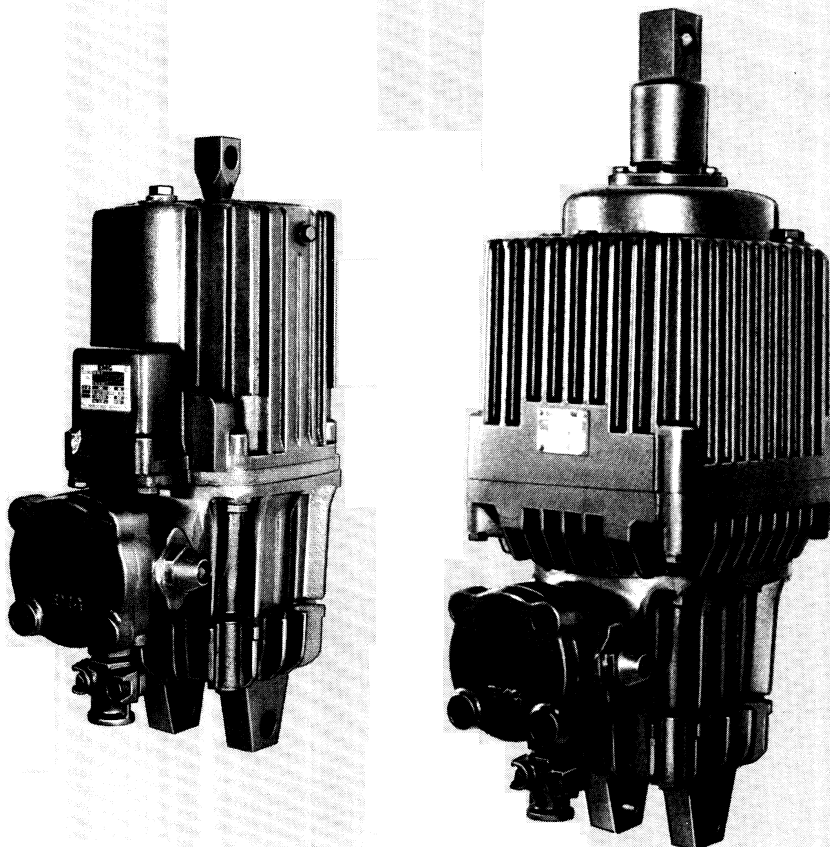

CERTIFICATE
Quality Assurance System
DIN ISO 9001 / EN 29001
Registration No. 70100 M 504

EMG

Description

Certificate of Conformity

HSE(M) No. 8650006X

The code of the electrical motor and terminal box is EEx d I
The code for the terminal enclosure with special cable gland (see page 7) is EEx e I

PTB No. Ex-90.C.3497

The code of the electrical motor and terminal box is EEx d II C T4
The code for the terminal enclosure with special cable gland (see page 7) is EEx e II

In this case the complete code of the electrical apparatus is EEx de II C T4

Complies with the following harmonized European Standards:
EN 50014 with appendix
EN 50018 with appendix
EN 50019 with appendix

Electrical design

Motor

Enclosure IP 44, DIN 40050 (IEC 529)
3 ph AC squirrel cage motor, construction according to VDE 0530 (IEC 34).

For performance details refer to technical data. Insulation class F.

Modes of Operation

Continuous operation S1 and intermittent service S3–60% duty cycle.
For duty rating refer to technical data.

Voltages and frequencies

400 V, 50 Hz, 3 ph AC

500 V, 50 Hz, 3 ph AC

690 V, 50 Hz, 3 ph AC

All units are on principle star (Y) connected at delivery.

Special windings 110 V–1000 V, 3 ph AC at extra charge.

60 Hz design at extra charge.

Terminal box

Enclosure IP 54, DIN 40050 (IEC 529)

3 supply terminals with connection screws M4.

Protective conductor terminal M4.

Earthing screw M6 (outside on terminal box).

Cable gland

For cable glands refer to page 7.

Motor circuit breakers

When protecting the units by motor circuit breakers the thermal trigger must be set at least on 1.5 times the holding current.

Mechanical Design

Assembly Dimensions

refer to dimension drawings.

Mounting Positions

Vertical: piston rod uppermost.

Horizontal and intermediate positions: rating plate to be on top.

Mounting Options

for units without limit switches

The base mounting can be rotated in steps of 90° (indicate when ordering).

The top pressure lug is rotatable.

Safety Measures

Piston rod chromium plated to size.

Dust proof double seal.

Double seal to oil chamber.

Piston rod protection tube and lifting marks with units Ed 121, Ed 201, Ed 301.

Coatings

Standard

Synthetic resin lacquer varnish, impact and scratch resistant.

Coating thickness ~ 40 μ.

Tint RAL 7022 (umbergrey).

Increased protection against Corrosion

Polyurethane lacquer (KOR).

Primer: one coat zinc phosphate.

Paint finish:

two coats polyurethane varnish.

Tint: RAL 7022 (umbergrey).

Other colours and coating 'Increased Protection against Corrosion' at extra charge.

Hydraulic fluid

The hydraulic fluid is filled at factory on principle.

Additional Equipment

All additional equipment is to be ordered separately at extra charge.

Lifting or Lowering Valve (H, S, HS)

Built-in lifting (H) and/or lowering (S) valves for stepless prolongation of normal lifting or lowering times. The adjustable minimum values obtain a level 10–20 times the standard values.

Built-in valves in setting 'open' result in increased lifting and lowering times for short stroke units of approx. 0.1 to 0.2 seconds and for long stroke units of approx. 0.2 to 0.4 seconds.

The valves are adjusted from the outside.

Braking Spring (c-Spring)¹⁾

The c-spring generates the braking force.

The specified force of the c-spring applies for 1/3 of the piston rod's rated lift stroke or 2/3 of the rated lower stroke.

Damping Spring (d-Spring)¹⁾

For aperiodic transient of the brake, this assists the brake to close smoothly.

Effective only in conjunction with a braking spring.

No limit switch can be annexed in this case.

There is no alteration in the mounting distance A.

When determining the operating point of the brake the dimension V is to be considered (see dimension drawing).

Main application: ELDRO-regulated brake.

¹⁾ Applies only to short-stroke units

Exchange Units

For spare orders for phased out units

refer to 'Ordering instructions for exchange units in explosion-proof design'.

Key to Types

Example:

Ed 80/6 c, d, H, S, EEx I

Ed ELDRO, 3 ph AC version

80/6 Type

c Brake spring (c-spring)

d Damping spring (d-spring)

H Lifting valve

S Lowering valve

EEx I For using in underground mines

EEx II For using in hazardous atmospheres

Characteristics

Technical Data

Type	Lifting Force N	Stroke mm	Thrust N cm	Brake spring Force (c-spring) ¹⁾ N	Power Consumption ²⁾ W	Current Consumption at 400 V ²⁾ A	Duty Rating at S3-60% Duty Cycle ³⁾ c/h	Weight ⁴⁾ kg
Ed 50/6	500	60	3000	460	275	1.2	1500	52
Ed 80/6	800	60	4800	750	280	1.2	1500	52
Ed 121/6	1250	60	7500	1200	310	1.3	1500	79
Ed 201/6	2000	60	12000	1900	385	1.3	1500	79
Ed 301/6	3000	60	18000	2700	470	1.3	1000	80
Ed 50/12	500	120	6000	—	275	1.2	900	63
Ed 80/12	800	120	9600	—	280	1.2	900	63
Ed 121/12	1250	120	15000	—	310	1.3	900	79
Ed 201/12	2000	120	24000	—	385	1.3	900	79
Ed 301/12	3000	120	36000	—	470	1.3	600	80

All technical data are mean values related to operating temperature of unit with hydraulic fluid Tellus C 10.

1) Values of braking force apply to 1/3 of the rated stroke.

2) Values at end-position of piston. During lifting operation the specified values multiply.

In the lower range of temperature the current and power consumption increases.

3) Continuous operation S1 and intermittent service S3 are permitted up to + 40°C ambient temperature.

4) Housing of grey cast

Approximate calculation for current consumption for non-standard voltages:

$$I_x = \frac{U_{(400\text{ V})}}{U_{(x)}} \cdot I_{(400\text{ V})}$$

Performance in Service depending on Ambient Temperature

Temperature range	Hydraulic fluid	Performance in service
- 20°C to + 40°C	Shell Tellus C 10	In the lower range of ambient temperatures the lifting times may increase up to four times the specified lifting times when the unit is operated the first time. The lowering times remain unaffected.

Housing Material

Ed 50, Ed 80, Ed 121, Ed 201, Ed 301	EEx I design	EEx II design
Motor housing	Ducile cast iron	Ducile cast iron
Hydraulic housing	Gray cast	Aluminium or gray cast ¹⁾

1) Grey cast housing at extra charge

c-Spring-Diagrams

Parameter values in Newtons (N)

- - - necessary force to compress c-spring
— force given from c-spring (braking force)

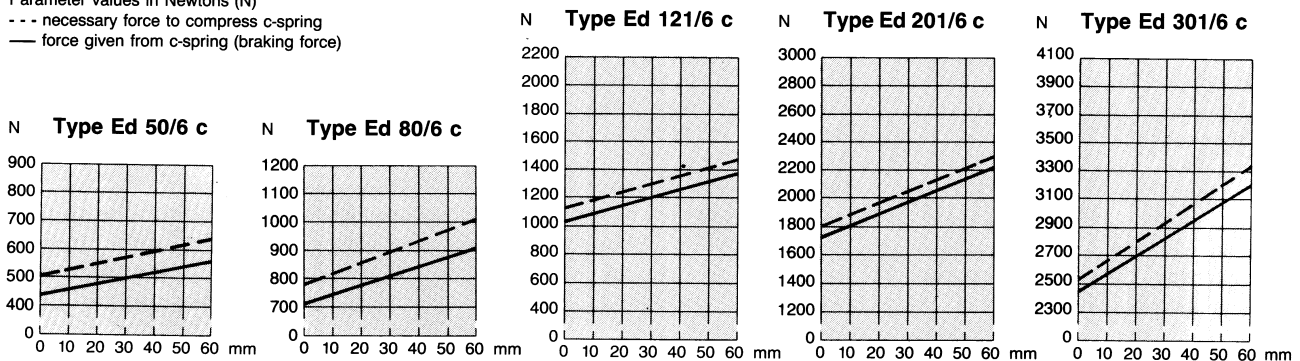

Characteristics

Stroke-Time-Diagrams

Diagrams taken under load at +20 °C operating temperature of unit with hydraulic fluid Shell Tellus C 10.

When applying the high-speed lowering circuit, the given lowering times are reduced by approx. 15%.

Types

Lifting

Lowering

Ed 50/6, Ed 80/6

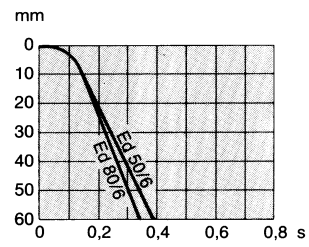
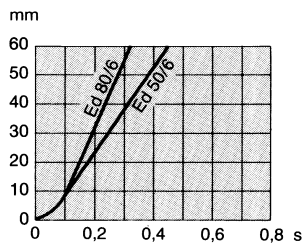

Ed 121/6, Ed 201/6, Ed 301/6

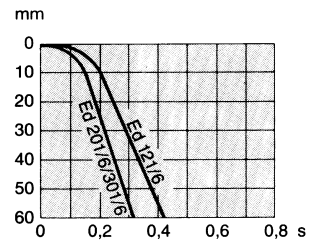
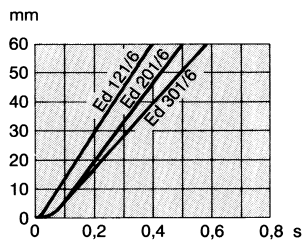

Ed 50/12, Ed 80/12

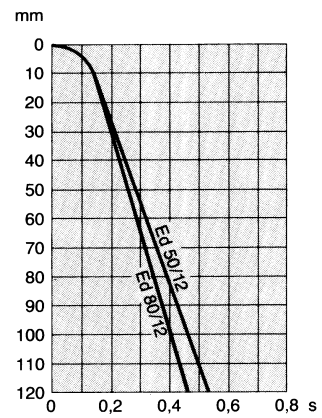
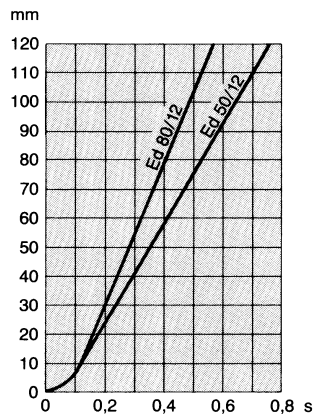

Ed 121/12, Ed 201/12, Ed 301/12

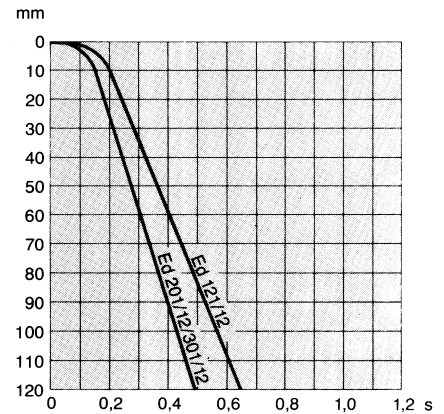
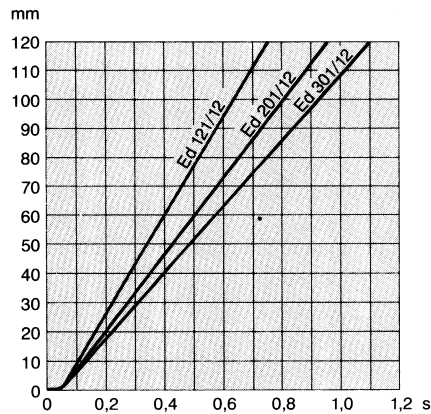

Dimension Drawings

Ed 50/6, Ed 80/6, Ed 50/12, Ed 80/12
Enclosure EEx I/EEEx II

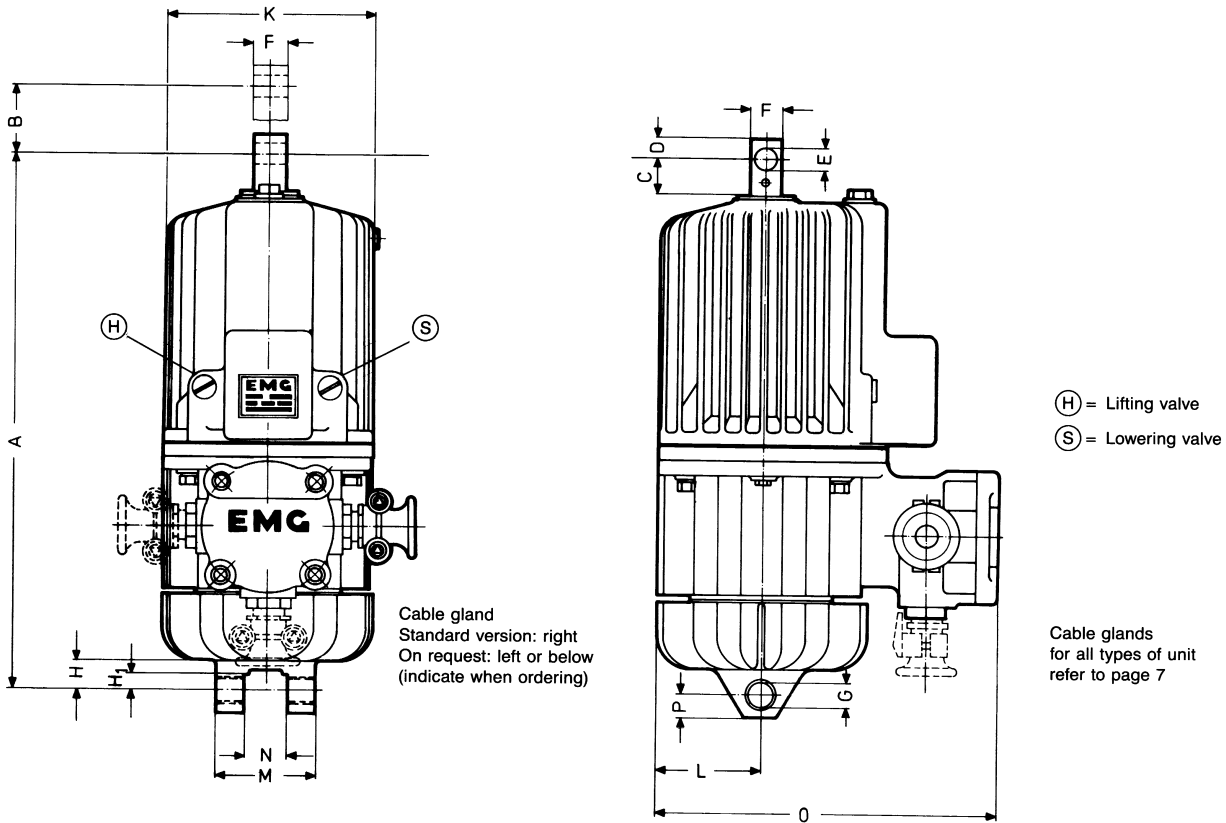

Damping-spring (d-spring) for all types of unit

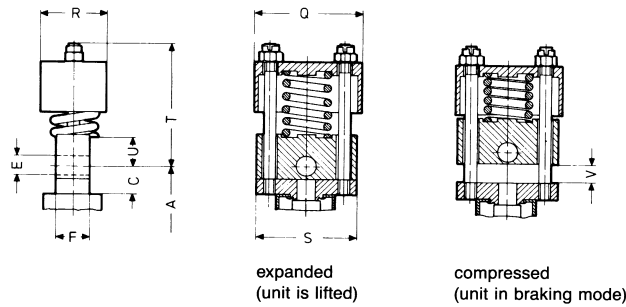

Dimension table

Type	A	B	C	D	E ¹⁾	F	G ¹⁾²⁾	H	H ₁	K	L	M	N	O	P	Q	R	S	T	U	V
Ed 50/6	509	60	36.5	18	20	30	24	45	35	190	95	120	60	310	22	85	55	75	100	22	15
Ed 80/6	509	60	36.5	18	20	30	24	45	35	190	95	120	60	310	22	85	75	75	100	22	15
Ed 50/12	609 ³⁾	120	36.5	18	20	30	24	45	35	190	95	120	60	310	22	—	—	—	—	—	—
Ed 80/12	609	120	36.5	18	20	30	24	45	35	190	95	120	60	310	22	—	—	—	—	—	—

1) Tolerance ^{+0.1}

2) Also available with clamping sleeve $\varnothing 20^{+0.1}$

3) On request also available with 570 mm

All dimensions in millimetres

Dimension Drawings

Ed 121/6, Ed 201/6, Ed 301/6, Ed 121/12, Ed 201/12, Ed 301/12
Enclosure EEx I/EEEx II

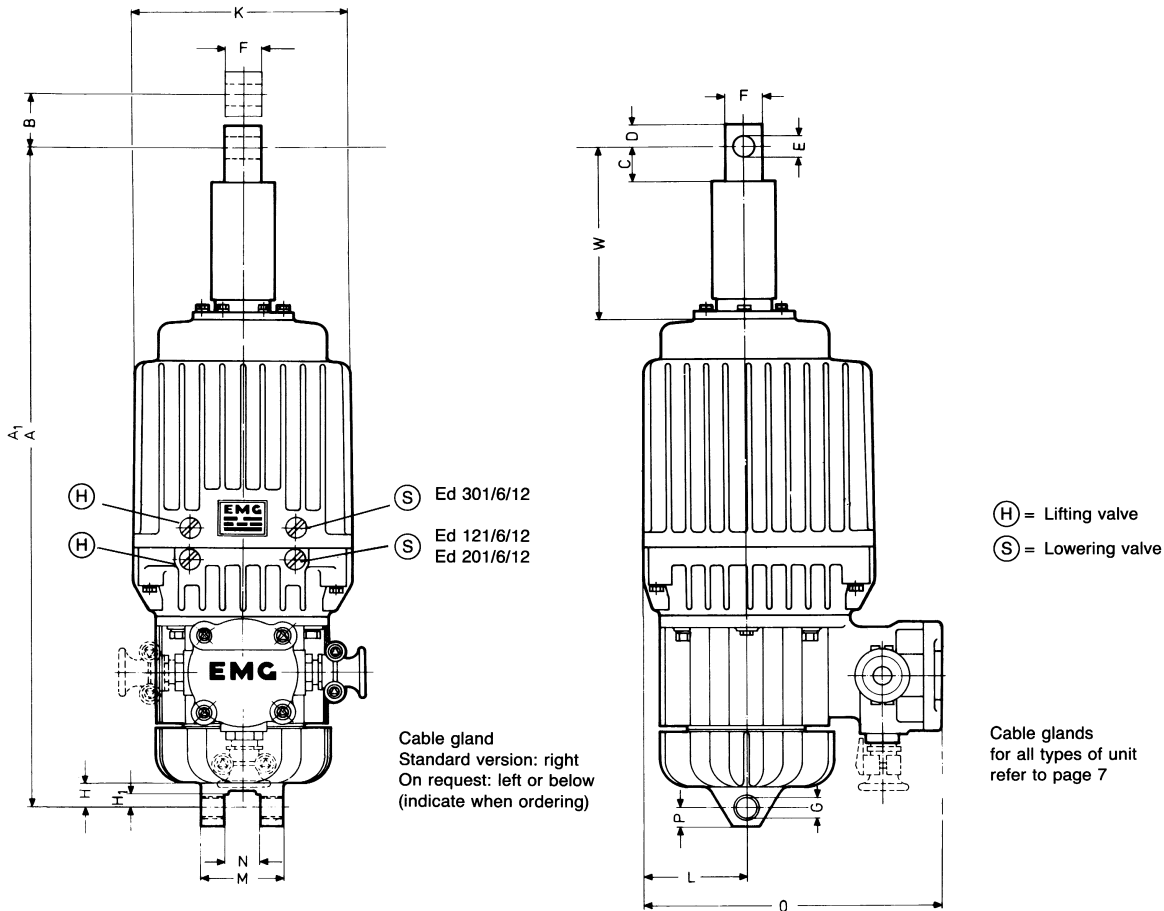

Damping-spring (d-spring)
for all types of unit

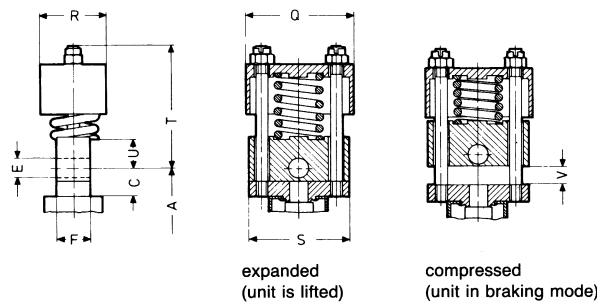

Dimension table

Type	A	B	C	D	E ¹⁾	F	G ²⁾	H	H ₁	K	L	M	N	O	P	Q	R	S	T	U	V	W	
Ed 121/6	690	60	38	25	25	40	25	45	35	240	112	90	40	324	30	130	80	120	147	35	20	130	
Ed 201/6	690	60	38	25	25	40	25	45	35	240	112	90	40	324	30	130	80	120	147	35	20	130	
Ed 301/6	690	60	38	25	25	40	25	45	35	240	112	90	40	324	30	130	80	120	147	35	20	130	
Ed 121/12	750	120	38	25	25	40	25	45	35	240	112	90	40	324	30	—	—	—	—	—	—	—	190
Ed 201/12	750	120	38	25	25	40	25	45	35	240	112	90	40	324	30	—	—	—	—	—	—	—	190
Ed 301/12	750	120	38	25	25	40	25	45	35	240	112	90	40	324	30	—	—	—	—	—	—	—	190

1) Tolerance ^{+0.1} 2) Tolerance ^{+0.25}/_{+0.15}

All dimensions in millimetres

Cable glands

Enclosure EEx d I

Insert for metal armored cables and lines.
Hawke type 6/470/653, size A
for cable diameter 14.6–21 mm
No. of approval HSE(M) 865002 U

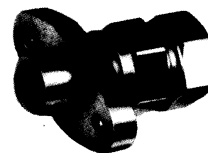

Insert for metal armored cables and lines.
Hawke type G 470/453, size A
with sealing compound
for cable diameter 14.6–21 mm
No. of approval HSE(M) 86512 U



Insert for non-armored cables and lines
(external sheathing seal).
Gothé type GSKZ d, design d54132. — —
with adapter¹⁾
for cable diameter 13–19 mm
No. of approval INIEX 84.103.361



Standard version

Enclosure EEx e I

Insert for non-armored cables and lines
(external sheathing seal).
Gothé type GSKZ d, design e54142. — —
with adapter
for cable diameter 13–19 mm
No. of approval INIEX 84.102.382



Enclosure EEx d II

Insert for metal armored cables and lines.
Hawke type ICG 653 and 653 T, size A
for cable diameter 14.6–21 mm
No. of approval BAS Ex 85 B 1258 U



Insert for metal armored cables and lines.
Hawke type 501/453, size A
with sealing compound
for cable diameter 14.6–21 mm
No. of approval BAS Ex 85 B 1259 U



Insert for non-armored cables and lines
(external sheathing seal).
Gothé type 54232. — —
with adapter¹⁾
for cable diameter 13–19 mm
No. of approval INIEX 89 B 103766



Standard version

Enclosure EEx e II

Insert for non-armored cables and lines
(external sheathing seal).
Gothé type 54242. — —
with adapter
for cable diameter 13–19 mm
No. of approval INIEX 89 B 102761



1) Standard version. Further cable glands on request.

Other EMG products and system resolving

DREHMO® Electro-mechanical Actuators
Servo Technique/Strip guiding for the metals industry
Diesel rail car equipment

Associated companies

BST, Bielefelder Servo-Technik GmbH
Web Guides for paper, foils, rubber, textiles

EMG-ELTMA Hebezeuge Oschersleben GmbH
Electro-hydraulic thrusters

EMH, Eletromecanica e Hidraulica, Belo Horizonte
Electro-mechanical and hydraulic components

Your local representative:

Elektro-Mechanik GmbH
Industriestraße 1
D-57482 Wenden
Phone (02762) 612-0
Telefax (02762) 612-320
Telex 876416
