

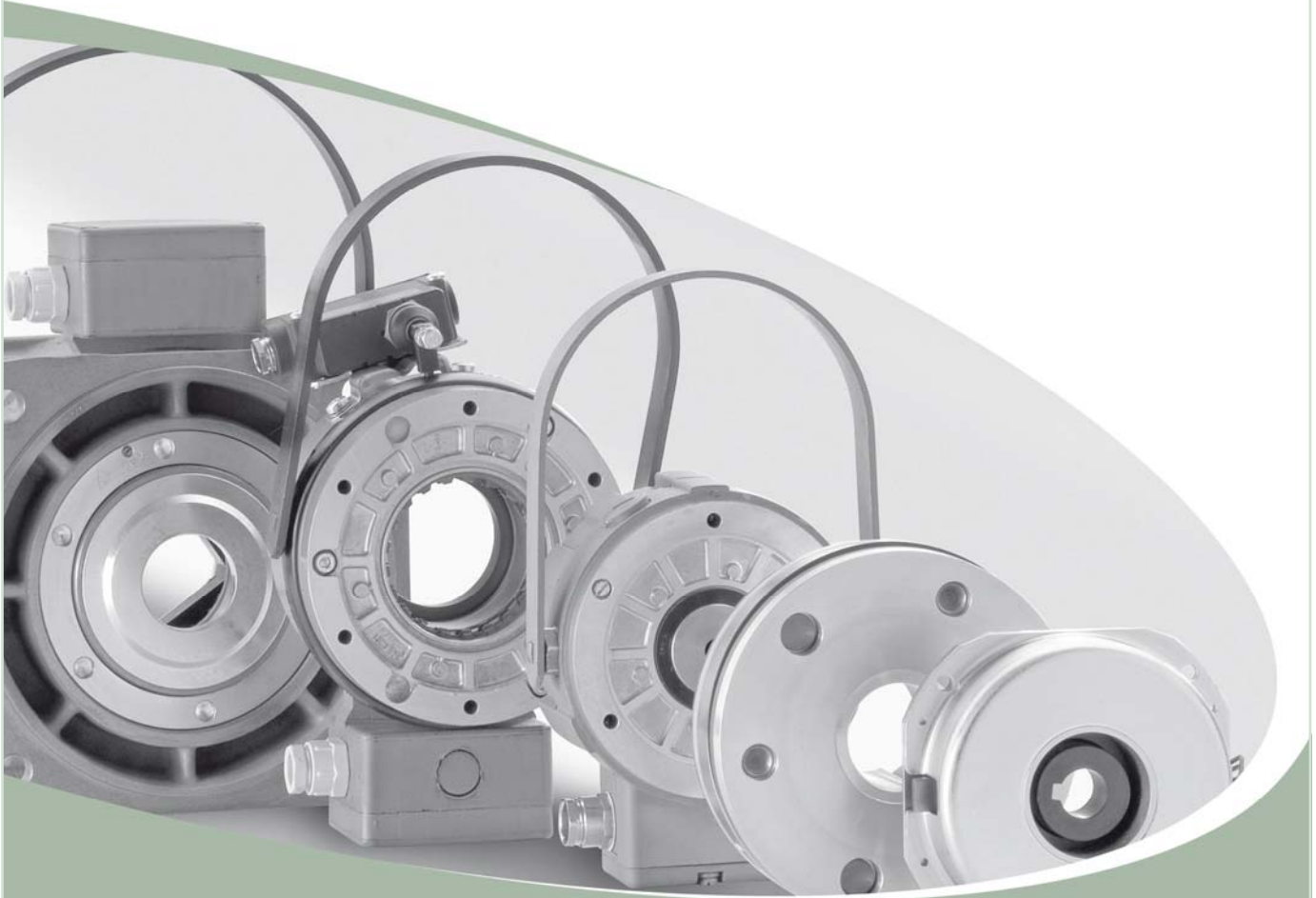

INDUSTRIAL DRIVE SYSTEMS



PM LINE

Operating Instructions 86 611..H00

## Permanent-magnet single-face brake

Types:	86 61106H00	86 61111H00
	86 61107H00	86 61114H00
	86 61109H00	86 61116H00



## Contents

<b>1.</b>	<b>General information .....</b>	<b>3</b>
1.1	Introduction .....	3
1.2	Standards and directives .....	3
1.3	Declaration of Incorporation (in accordance with Annex II, part 1, Section B of Machinery Directive 2006/42/EC).....	3
1.4	Manufacturer's liability .....	3
<b>2.</b>	<b>Product description .....</b>	<b>4</b>
2.1	Operating principle.....	4
2.2	Brake design.....	4
<b>3.</b>	<b>Installation.....</b>	<b>5</b>
3.1	Mechanical installation.....	5
3.2	Electrical connection and operation.....	7
3.2.1	DC power supply .....	7
3.2.2	AC power supply.....	8
3.3	Electromagnetic compatibility .....	10
3.4	Set-up and start-up .....	13
<b>4.</b>	<b>Maintenance.....</b>	<b>14</b>
4.1	Checks and service .....	14
4.2	Spare parts, accessories .....	14
<b>5.</b>	<b>Condition at delivery .....</b>	<b>14</b>
<b>6.</b>	<b>Emissions.....</b>	<b>15</b>
6.1	Noise.....	15
6.2	Heat .....	15
<b>7.</b>	<b>Troubleshooting .....</b>	<b>15</b>
<b>8.</b>	<b>Safety.....</b>	<b>16</b>
8.1	Intended use .....	16
8.2	General safety information.....	16
8.2.1	Set-up .....	16
8.2.2	Set-up and start-up .....	17
8.2.3	Installation.....	17
8.2.4	Operation .....	17
8.2.5	Maintenance and repair .....	18
8.3	Warning symbols .....	18
<b>9.</b>	<b>Definitions .....</b>	<b>19</b>
<b>10.</b>	<b>Technical specifications.....</b>	<b>21</b>
<b>11.</b>	<b>Authorised repair shops for maintenance work .....</b>	<b>22</b>

Issued by: Kendrion Binder Magnete GmbH  
Industrial Drive Systems  
Replaces the issue dated: 12 February 2008  
Translation of original German operating instructions issue dated: 30 December 2009

## 1. General information

### 1.1 Introduction

These Operating Instructions describe the operating principle and features of the 86 611..H00 series of Kendrion Binder permanent-magnet single-face brakes. The safety information provided in this manual must be strictly observed during the set-up of the machine (e.g. motor) and during the start-up, operation and maintenance of the permanent-magnet single-face brake. Should any queries arise with respect to torques, torque variations, installation position, wear, wear reserve, switching work, break-in conditions, release torque, ambient conditions and the like, please contact Kendrion Binder and ask for clarification before starting to use the brake. Kendrion Binder permanent-magnet single-face brakes in the 86 611..H00 series are not ready-to-use devices, but are intended to be incorporated into or assembled with other equipment.

### 1.2 Standards and directives

The state-of-the-art permanent-magnet single-face brakes have been designed, built and tested in accordance with the requirements of DIN VDE 0580 concerning electromagnetic devices and components. Being classified as "electromagnetic components", permanent-magnet single-face brakes are not subject to the Low Voltage Directive and must not bear a CE mark of conformity. The user is required to employ suitable switching devices and controls to ensure use of the brakes in accordance with EMC Directive 2004/108/EC.

### 1.3 Declaration of Incorporation (in accordance with Annex II, part 1, Section B of Machinery Directive 2006/42/EC)

We hereby declare that the products below comply with the essential health and safety requirements specified in Annex I of Machinery Directive 2006/42/EC:

Annex I General Principles, Annex I Sections 1.1.2, 1.1.3, 1.1.5, 1.3.2, 1.5.1

The partly completed machinery must not be put into service until the final machinery into which it is to be incorporated has been declared in conformity with the provisions of Machinery Directive 2006/42/EC. The relevant technical documentation required for the partly completed machinery has been compiled in accordance with Annex VII, part B of Machinery Directive 2006/42/EC. The manufacturer undertakes to submit an electronic copy of the relevant technical documentation compiled for the partly completed machinery if reasonably requested by national authorities.

**Manufacturer:** Kendrion Binder Magnete GmbH  
Industrial Drive Systems  
Mönchweilerstr. 1  
78048 Villingen-Schwenningen  
Germany

**Person authorised to compile the documentation:** Dr. Matthias Dannemann  
Kendrion Binder Magnete GmbH  
Industrial Drive Systems  
Mönchweilerstr. 1  
78048 Villingen-Schwenningen  
Germany

#### Standards and regulations:

EN 60529 Enclosure protection ratings  
DIN VDE 0580 Electromagnetic devices and components

**Products:** Permanent-magnet single-face brake  
86 61106H00                      86 61111H00                      86 61107H00  
86 61114H00                      86 61109H00                      86 61116H00

Kendrion Binder Magnete GmbH  
Industrial Drive Systems

Villingen, 30 Dec. 2009 by proxy

  
.....  
Dr. Matthias Dannemann  
(Head of Development at IDS)

### 1.4 Manufacturer's liability

The manufacturer will not assume any responsibility for damage caused by failure to use the products in accordance with their intended use or by failure to observe safety information and other instructions provided in this manual. The information in this manual was correct and up-to-date before going to print. The information contained herein shall not entitle users to raise claims with respect to components purchased at an earlier date.

## 2. Product description

### 2.1 Operating principle

The permanent-magnet single-face brake is designed to operate dry. The force generated by a permanent magnetic field is utilised to produce the braking effect. To neutralise the braking action, the magnetic flux of the permanent magnets is cancelled by an alternate electromagnetic field (electromagnetically released system). The zero backlash connection between the armature and flange hub ensures zero backlash transmission of the brake torque to the machine shaft (e.g. motor shaft) and reliable release of the permanent-magnet single-face brake with zero residual torque. Thanks to these features, permanent-magnet single-face brakes are ideal for servo motor applications.

### 2.2 Brake design

The firmly fitted field coil (1.2) is installed between the outer ring (2) and inner ring (3) of the permanent-magnet single-face brake. The flying leads required to connect the field coil (1.2) exit on the brake circumference. The permanent magnets (1.1) installed in axial direction between the outer ring (2) and the flange of the inner ring (3) generate the magnetic field required to produce the braking action. The armature (4) is connected with the flange hub (5) by means of segmental springs (7) and rivet fasteners (6) to establish an axially movable, torsion-proof and friction-free connection. This ensures zero residual torque during horizontal or vertical brake operation. The rated air gap 's' between the armature (4) and outer ring (2) of the permanent-magnet single-face brake is adjusted during brake mounting (e.g. through mounting tolerances). The flange hub (5) is attached to the machine shaft (e.g. motor shaft) in such a way that a torsion-proof and axially fixed connection is achieved. The permanent magnetic field attracts and pulls the armature (4) in frictional contact with the outer ring (2) or inner ring (3) to generate the brake action. When DC voltage is applied to the field coil (1.2) of the permanent-magnet single-face brake, the alternate electromagnetic field offsets the force exerted on the armature (4) by the permanent magnetic field and the brake is released. Except for the minimal force exerted by the segmental springs (7), the shaft (12) to be braked is not exposed to any other axial force.

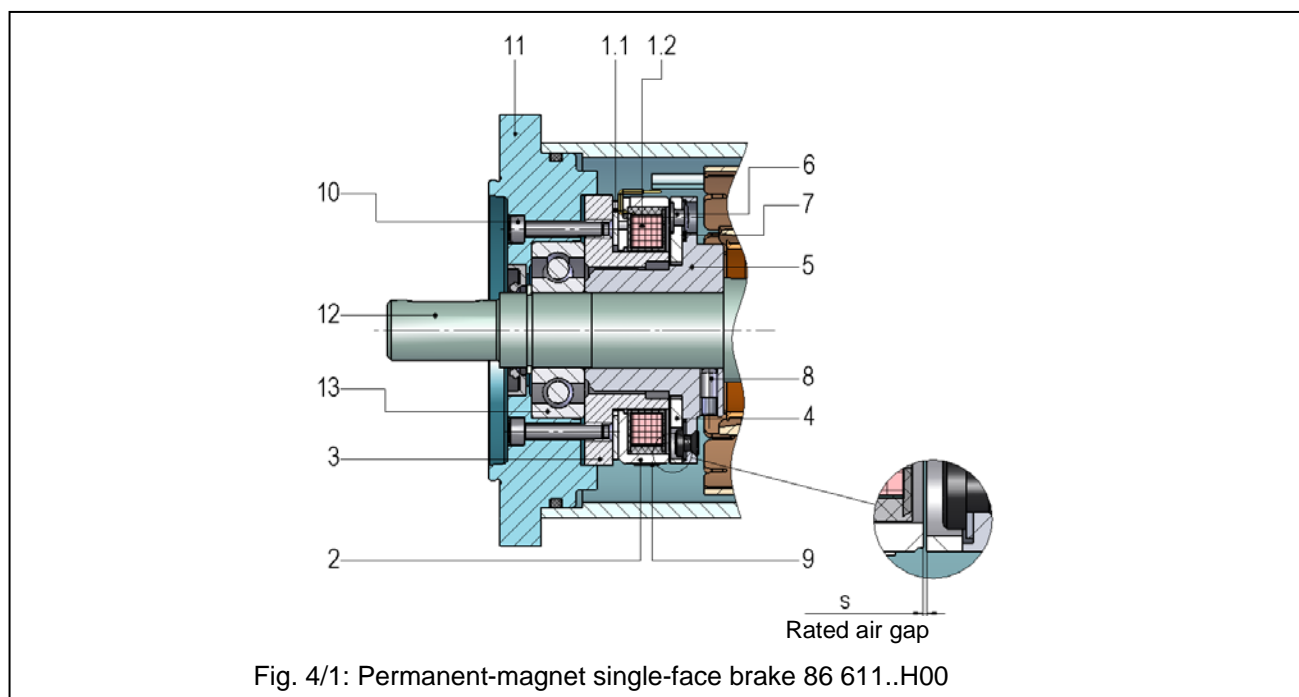

Fig. 4/1: Permanent-magnet single-face brake 86 611..H00

#### Key to Fig. 4/1:

1.1	Permanent magnet	7	Segmental spring
1.2	Field coil	8	Set screw
2	Outer ring	9	Rating plate
3	Inner ring	10	Fixing screws
4	Armature	11	Fixing surface (e.g. motor end shield)
5	Flange hub	12	Shaft
6	Rivet fastener	13	Bearing (e.g. deep groove ball bearing of motor)

### 3. Installation

#### 3.1 Mechanical installation

After having centred the brake field coil with the motor end shield (11) over the outer diameter  $d_1$  of the inner ring (3) (see PM Line specification sheet), the entire assembly must be screwed to the motor end shield (11) by means of the fixing screws (10) (e.g. machine screws to ISO 4762; property class 8.8). The fixing screws (10) must be tightened evenly in diametrically opposite sequence applying the  $M_A$  tightening torques and using the thread lengths specified in Table 5/1. The flange hub (5) with armature (4) must be slipped on the motor shaft (12) and secured axially by means of the set screws (8). If a flange hub (5) without feather key groove is used, the hub (5) must be pressed (press fit or shrink fit) onto the motor shaft (12) without set screw (8). The motor shaft (12) and the motor end shield (11) must be dimensioned in such a way that the rated air gap 's' (see Table 21/1) is automatically adjusted as the flange hub (5) stops against the inner ring of the bearing (13) when the motor end shield (11) and core assembly of the permanent-magnet single-face brake are installed (brake mounting on fixed bearing side). If necessary, shim rings can be installed between the contact surface of the shaft (12) and the flat face of the flange hub (5).

	Size					
	06	07	09	11	14	16
Thread length [mm]	4.5	3.5	3.5	6.5	9.5	10
$M_A$ tightening torques – fixing screws (10) [Nm]	1.5	1.5	1.5	3.5	6.5	6.5
Set screw thread (8)	M3	M4	M5	M6	M8	M8
$M_A$ tightening torques – set screw (8) [Nm]	0.9	2	4	7	17	17

Table 5/1:  $M_A$  tightening torques of fixing screws (10) and set screw (8); thread length of fixing screws (10) (property class 8.8)



#### Note!

The axial runout of the pole faces of the permanent-magnet brake relative to the shaft (12) must not exceed 0.05 mm after the screws have been tightened.



#### Warning!

Any deformation of the outer ring (2) or inner ring (3) during brake installation must be avoided. Deformation may be caused by an excessive tightening torque on the fixing screws (10) and may adversely affect the brake torque.



#### Caution!

The fixing screws (10) and set screws (8) must be tightened evenly in diametrically opposite sequence applying the  $M_A$  tightening torques and following the thread length specifications in Table 5/1. The set screws (8) must not be too long to prevent contact between the set screws (8) and inner ring (3) during operation. The fixing surface (11) (e.g. motor end shield) must be dimensioned in such a way that the screw connection is not affected by setting effects and the like.

**Warning!**

Brake torque transmission over the flange hub (5) to the machine shaft (12) (e.g. motor shaft): When a pressed-on flange hub (5) and secured set screws (8) are used, the tolerance of the shaft (12) and the type of set screw (8) used (e.g. set screws with hexagon socket to DIN 916; property class 45H) must be selected to ensure reliable transmission of the generated brake torques. The set screws (8) must be provided with a thread locker (e.g. micro-encapsulated set screws) to DIN 267, part 28. The pole faces must be kept free of adhesive residues and the like at all times, especially during brake operation at the maximum permitted speed  $n_{\max}$  (see Table 21/1 "Technical specifications"). The set screws (8) must not project from the thread bores of the flange hub (5). The effective thread length of the set screws (8) must enable reliable transmission of the  $M_A$  tightening torque on a long-term basis. Any thread bore defects must be eliminated. If necessary, the shaft (12) must be adjusted in such a way that any projection of the set screws (8) is avoided (e.g. necking of the shaft (12)).

**Note!**

During brake installation, all parts must be axially secured and axial bearing play must be eliminated. The inner ring of the bearing (13) (e.g. motor bearing) must be kept preloaded by using suitable mechanical parts. Make sure that lubricants and the like cannot seep from the bearing (13) (e.g. motor bearing) into the brake. (Sealed bearings can be used to prevent lubricant leaks.)

**Note!**

Magnetic interference fields may affect reliable brake operation. Consequently, the brake should always be installed outside the reach of magnetic interference fields. The assembled brake components, especially the friction surface, must be free of grease and oil. During installation of the flange hub (5) with armature (4), any deformation of the segmental springs (7) must be avoided. The air gap must not be larger or smaller than the rated air gap 's' (see Table 21/1 "Technical specifications").

### 3.2 Electrical connection and operation

The permanent-magnet single-face brake must be connected to smoothed DC voltage in accordance with Table 7/1. It is also possible to apply bridge-rectified supply voltage (see Table 7/2).

Flying leads	Polarity
Blue flying lead of brake	-
Red flying lead of brake	+

Table 7/1: Polarity of flying leads



#### Note!

The correct polarity of the flying leads (see Table 7/1) is important to ensure reliable brake operation.

Various rectifier versions are available (see examples Table 7/2) to allow the brake to be connected directly to an AC power source. Depending on the brake size and torque, voltage ripple due to intermittent power supply may cause brake humming or incorrect brake operation. Perfect brake operation must be ensured by the user or system manufacturer by providing suitable electrical controls.

Rectifier series	Rectifier type	Rated input voltage range $U_1/VAC$ (40-60 Hz)	Output voltage $U_2/VDC$	Max. output current	
				R-load I/ADC	L-load I/ADC
32 07.23B.0	bridge	0-400 ( $\pm 10\%$ )	$U_1 \cdot 0.890$	1.6	2.0
32 07.03B.0	bridge	0-500 ( $\pm 10\%$ )	$U_1 \cdot 0.890$	1.6	2.0

Specific rectifier specification sheets must be observed!

Table 7/2: Recommended rectifiers for single-phase AC voltage supply

#### 3.2.1 DC power supply

The figure to the right shows the voltage curve after the field coil (1.2) has been de-energised.



#### Attention!

The peak voltage  $U_{Vmax}$  during disconnection without protective circuit may reach **several thousand V** in the millisecond region. This may cause irreversible damage to the field coil (1.2), switching contacts and electronic components. Sparking will occur on the switch during disconnection. Consequently, a protective circuit must be provided to reduce the current during disconnection and to limit the voltage. The maximum permitted overvoltage during disconnection is 1500 V. If Kendrion Binder rectifiers are used (see Table 7/2), the protective circuit required for the built-in electronic components and field coil (1.2) is included in the rectifier. This does not apply to the external contacts required for DC side switching as there would be no galvanic isolation of the external contact.

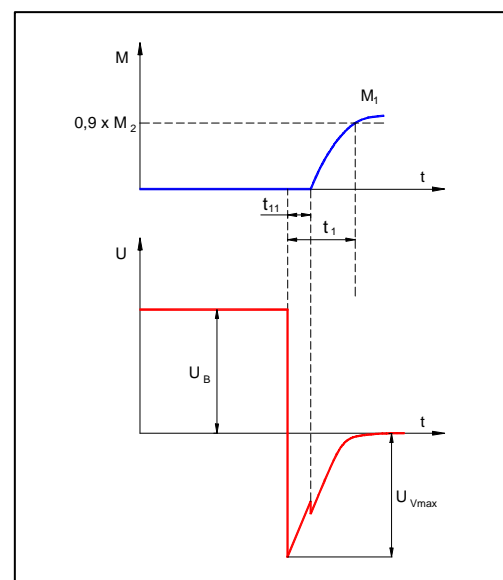

$U_B$  operating voltage (coil voltage)  
 $U_{Vmax}$  disconnection voltage

**Attention!**

Sensitive electronic components (e.g. logical components) may also be damaged by the lower voltage.

### 3.2.2 AC power supply

Direct brake connection to an AC power source is only possible if a bridge rectifier is used. Wiring of the brake in case of single-phase AC power supply must be performed in the same way as with three-phase voltage. The coupling times vary depending on the switching type (DC side switching or AC side switching).

#### Bridge rectification:

Bridge rectifiers provide voltage with minimum residual ripple. This allows brake humming to be avoided even if small size brakes are used. In case of bridge rectification, the  $U_2$  coil voltage is lower by factor 0.89 than the rectifier input voltage.

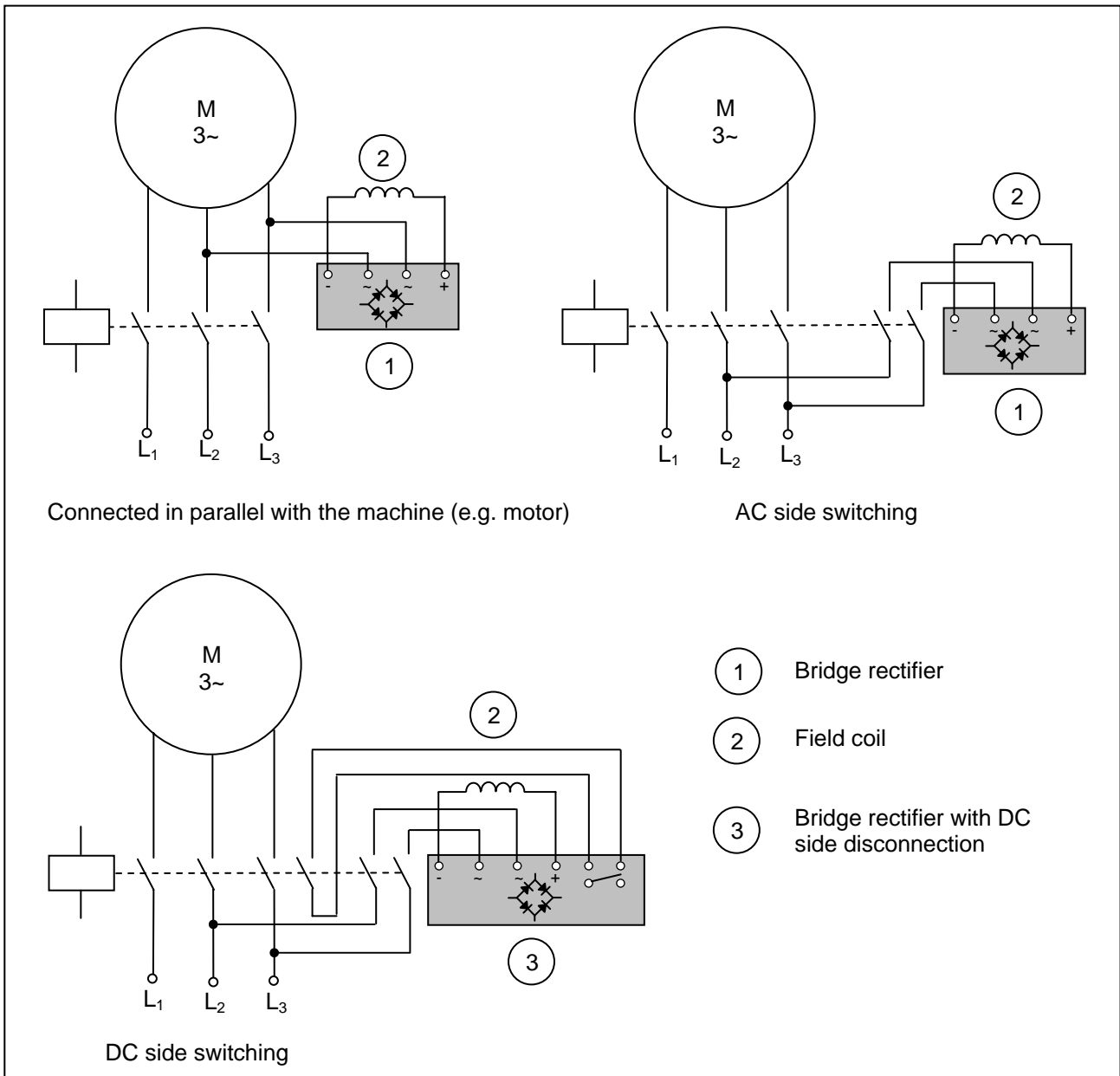

### AC side switching:

The easiest wiring method is to connect the rectifier in parallel with the brake in the terminal box of the machine (e.g. motor). It must be considered, however, that the motor may act as a generator after AC voltage has been removed and thus extend the coupling times significantly (by factor 5 or over). The disconnection times remain unchanged.

### DC side switching:

In case of DC side brake switching, an auxiliary contact is provided on the motor contactor, for example. This auxiliary contact is designed to interrupt the power supply on the DC side.



#### **Attention!**

In case of DC side switching, the brake must be provided with a protective circuit to avoid overvoltage. Additional protective elements (e.g. varistors, spark arresters, etc.) must be installed to avoid damage such as burns or welded contacts.



#### **Warning!**

Work on the brake must only be carried out by suitably qualified personnel. Make sure that no voltage is applied during brake connection. The specifications on the rating plate and the information provided in the circuit diagram in the terminal box or in the Operating Instructions must be strictly observed.



#### **Warning!**

The brake is a DC operated system. Permanent voltage variations on the power source of the electromagnetic brake must be limited to +/-10% of the rated voltage.

The following checks must be carried out when connecting the brake:

- Check that the connecting cables are suitable for the intended use and for the voltage and amperage of the brake.
- Check that the connecting cables are secured with screws, clamps or other suitable fixtures to avoid interruptions in the power supply.
- Check that the connecting cables are long enough for the intended use and that suitable torsion, strain and shear relief features as well as bending protections are provided.
- Check that the PE conductor (only for protection class I) is connected to the earthing point.
- Check that no foreign matter, dirt or humidity is trapped inside the terminal box.
- Check that unused cable entries and the terminal box are suitably sealed to ensure compliance with the protection class requirements to EN 60529.

### 3.3 Electromagnetic compatibility

As required by the German Electromagnetic Compatibility Act (EMVG), electromagnetic compatibility is essential to ensure immunity to external electromagnetic fields and conducted interference. Furthermore, the emission of electromagnetic fields and line-conducted interference during brake operation must be minimised. Since the brake features depend on the circuitry and operation, a declaration of conformity with the applicable EMC standard can only be furnished for the wiring type, but not for a specific brake. The permanent-magnet single-face brakes in the 86 611..H00 series are designed for industrial applications to which the following EMC standards apply: Generic Immunity Standard VKE 0839, part 6-2 (EN 61000-6-2), and Generic Emission Standard VDE 0839, part 81-2 (EN 50081-2). Other applications may be subject to different generic standards which must be considered by the manufacturer of the overall system. The requirements in terms of electromagnetic compatibility of devices and components are determined by basic standards derived from the generic standards. Brake wiring recommendations will be provided in the following sections to ensure compliance with the individual basic standards that are relevant for industrial brake use and other applications. Please refer to the specification sheets for additional information on electromagnetic compatibility, especially with respect to the recommended electronic rectifiers specified in Section 3.2.

#### Immunity according to EN 61000-4:

##### EN 61000-4-2 Electrostatic discharge:

The permanent-magnet single-face brakes in the 86 611..H00 series comply at least with severity level 3 without requiring additional measures. The recommended rectifiers specified in Section 3.2 conform to severity level 3 without additional measures.

##### EN 61000-4-3 Electromagnetic fields:

The brakes comply at least with severity level 3 without requiring additional measures. The recommended rectifiers conform to severity level 3 without additional measures.

##### EN 61000-4-4 Fast transients (burst):

The brakes comply at least with severity level 3 without requiring additional measures. The recommended rectifiers conform to severity level 3.

##### EN 61000-4-5 Surge:

The brakes comply at least with severity level 3 without requiring additional measures. The recommended rectifiers conform to severity level 3.

##### EN 61000-4-9 Pulse magnetic fields, EN 61000-4-10 Damped oscillatory magnetic fields:

Since the operating magnetic fields of the electromagnetic brakes are stronger many times over than interference fields, the brake function will remain unaffected. The brakes comply at least with severity level 4. The recommended rectifiers conform at least to severity level 3.

##### EN 61000-4-11 Voltage dips, short interruptions, and short supply voltage variations:

###### a) Voltage interruptions:

Brakes that comply with the requirements of DIN VDE 0580 are de-energised after the specified switching times at the latest. The switching time depends on the control and mains conditions (e.g. generator effect of running down motors). Voltage interruptions of shorter duration than the response delay specified by DIN VDE 0580 will not cause any malfunctions. The user must ensure that any damage is avoided (e.g. motor start-up before the brake has been released caused by phase failure in the case of two-phase energised motors or by the slipping of an electromagnetically engaged system due to torque drop). The functional reliability of the electromagnetic brake and its electronic accessories remains unaffected provided that any damage is avoided.

###### b) Voltage dips and short supply voltage variations:

Electromagnetically released systems:

Voltage dips and supply voltage variations to below 60% of the rated voltage and lasting longer than the response delay specified by DIN VDE 0580 may cause the brake to be de-energised temporarily. Damage as described under a) above must be avoided by the user by taking adequate precautions.

Electromagnetically engaged systems:

Voltage dips and supply voltage variations to below the minimum tolerance threshold will cause torque reductions. The user is required to take adequate precautions to avoid consequential damage.

### Radio interference suppression in accordance with EN 55011:

The brakes and the recommended electronic rectifiers are classified as Group 1 equipment in accordance with EN 55011. As far as the emissions from this equipment are concerned, one distinguishes between field guided radiated interference and line-conducted interference.

a) Radiated interference:  
When operated with DC voltage or rectified 50/60 Hz AC voltage, all brakes comply with the limit values applicable to Class B equipment.

b) Conducted interference:  
When connected to a DC power source, the electromagnetic brakes meet the limit values applicable to Class A equipment. If the brakes are connected to a 50/60 Hz AC power source and equipped with electronic rectifiers or other electronic controls, interference suppression measures as shown in Fig. 11/1 must be taken to ensure compliance with the limit values applicable to Class A equipment. Interference suppression capacitors should be used which must be dimensioned to suit the connection data of the electromagnetic components and the specific mains conditions. The recommended rectifiers specified in Section 3.2 are CE mark certified in accordance with the EMC Directive. They have built-in interference suppression components and comply at least with the requirements of EN 55011 for Class A equipment, unless otherwise specified in the specification sheet. When brakes are used with the specified rectifiers or with other types of rectifiers, the recommended values listed in Table 12/1 should be observed. Interference suppression components should be installed as close as possible to the consumer. Interference caused during switching operations of the electromagnetic component is generally attributable to the inductive load. Where necessary, assemblies designed to limit the disconnection voltage (e.g. anti-parallel diode) or voltage limiting components (e.g. varistors, suppressor diodes, resistance diodes and the like) can be installed. However, such components will inevitably change the switching times of the brake and increase the generated noise level. The rectifiers specified in Section 3.2 are equipped with free-wheel diodes and/or varistors to limit the disconnection voltage. In case of DC side switching, a varistor rated for the type-specific maximum operating voltage and connected in parallel with the field coil (1.2) limits the peak voltage to the values specified in Table 12/2.

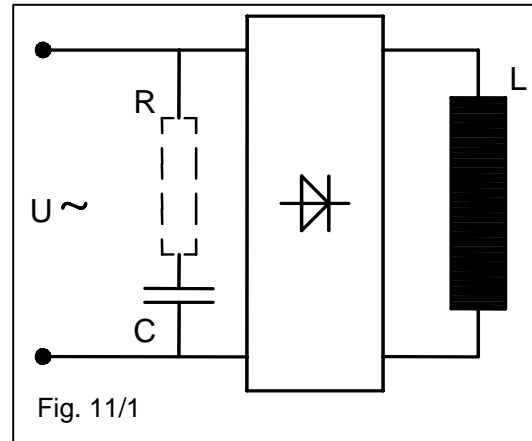

If the brake is used in connection with other electronic accessories, the user is responsible to ensure compliance with EMC requirements. Compliance with applicable standards concerning the design and operation of components, sub-assemblies or equipment employed shall not relieve the user and manufacturer of the overall system from their obligation to furnish proof of conformity of the overall system with such standards.

Rectifier type	Rated input voltage range $U_1/VAC$ (40-60 Hz)	DC at L-load (ADC)	Capacitor (nF(VAC))
Bridge rectifier 32 07.23B.0	up to 400 ( $\pm 10\%$ )	up to 2.0	no additional interference suppression measures required
Bridge rectifier 32 07.03B0.	up to 230 ( $\pm 10\%$ ) up to 500 ( $\pm 10\%$ )	up to 2.0 up to 2.0	47/250~ 100/500~

Table 12/1

Max. rectifier operating voltage (VAC)	Recommended disconnection voltage for DC side switching (V)
250	700
440	1200
550	1500

Table 12/2

### 3.4 Set-up and start-up



#### Warning!

The functional check of the brake must not be performed unless the machine (e.g. motor) has been switched off and secured against accidental or unintentional start-up.

The following checks must be carried out:

Check compliance with the specifications provided on the rating plate with respect to the mounting position and protection class. After connection of the brake, a functional test must be performed to check that the flange hub (5) with armature (4) is not blocked. For this purpose, turn the shaft (12) while the brake is energised and the machine (e.g. motor) is unpowered. After completion of mounting, all necessary covers and guards must be installed.



#### Warning!

Before starting the machine (e.g. motor) test run without driven components, the feather key (if used) must be secured in such a way that it cannot be hurled out. The shaft (12) must not be exposed to load torques. Before the machine (e.g. motor) is re-started, the brake must be de-energised.



#### Caution!

The brake surface temperature may rise to over 100°C. Heat-sensitive parts such as conventional cables or electronic components must not be fixed to or be in contact with these surfaces. If necessary, suitable protections and hand guards must be installed to avoid accidental contact with hot surfaces! If the shaft (12) needs to be turned during set-up operations, the brake must be energised.



#### Attention!

High-voltage tests performed during brake installation within an overall system or during start-up must be carried out in such a way that damage to the built-in electronic accessories is avoided. The limits for high-voltage tests and follow-up tests specified by DIN VDE 0580 must be observed.



#### Attention!

Check that the brake has been connected in accordance with the specifications provided on the rating plate before it is put into operation. Even short-term operation outside the specified supply voltage limits may cause irreversible damage to the brake or electronic accessories. Such damage may not be apparent immediately. DC side brake switching without protective circuit as described in Section 3.3 will cause damage to electronic rectifiers or other electronic accessories, switching contacts and to the field coil (1.2). The opening (release) and braking behaviour of the permanent-magnet single-face brake is affected by magnetic interference fields through magnetically conductive components (e.g. motor shaft (12)). In such cases, the magnetic specifications of the brake must be factory-adjusted to the specific installation conditions.

## 4. Maintenance

### 4.1 Checks and service

The permanent-magnet single-face brake does not require any particular maintenance except that the air gap 's' must be measured at regular intervals. If the maximum air gap  $s_{max}$  (see Table 21/1 "Technical specifications") between the armature (4) and outer ring (2) of the permanent-magnet single-face brake has been reached, the brake must be replaced by a new one. If the brake is not operated for a long period of time, the pole faces of the inner ring (3) and/or outer ring (2) may corrode and reduce the brake torque. A short break-in process (see Table 21/3) will restore correct and reliable brake operation.



#### Warning!

Depending on the brake operating condition, correct brake action (brake function) may be compromised or even lost when the maximum air gap  $s_{max}$  (see Table 21/1 "Technical specifications") is exceeded.



#### Caution!

Whenever inspection and maintenance work is carried out, check that

- the machine (e.g. motor) is secured against accidental or unintentional start-up.
- no load torque is applied to the shaft (12).
- the lock provided to prevent accidental start-up of the machine (e.g. motor) is removed after completion of inspection and maintenance work.
- all friction surfaces are free from grease and oil.

### 4.2 Spare parts, accessories

The permanent-magnet single-face brake does not require any maintenance if operated in accordance with its intended use. If defects occur on the brake or individual components, the entire brake needs to be replaced. Individual spare parts or accessories are not available.

## 5. Condition at delivery

Upon receipt of the shipment, the brake must be checked for transit damage before storage. The permanent-magnet single-face brake is delivered ready for mounting. The rated air gap 's' (see Table 21/1 "Technical specifications") must be adjusted during brake installation. After the brake has been installed it requires a break-in process using the break-in parameters specified in Table 21/3.



#### Note!

The brake field coil and the flange hub with armature are factory-adjusted to ensure reliable brake opening (release). Consequently, individual components cannot be replaced. If the brake is not installed immediately upon delivery, it must be stored in a dry, dust-free and vibration-proof place.

## 6. Emissions

### 6.1 Noise

The permanent-magnet single-face brake produces switching noise during engagement and release. The noise level is determined by the installation conditions, circuitry and air gap. Depending on the installation position, operating conditions and quality of the friction surfaces, clearly audible vibrations (squeaking) may be produced during braking.

### 6.2 Heat

Braking operations and gradual heating of the field coil cause the brake temperature to increase substantially. Under adverse conditions, the surface temperature may rise to well over 100°C.



#### Caution!

Risk of burns in case of contact with hot surfaces! Suitable covers and hand guards must be installed to provide protection against accidental contact.

## 7. Troubleshooting

Fault	Cause	Corrective actions
Brake engagement failure	• Air gap too large	Check the air gap. Install a new brake, if necessary.
	• Voltage applied to brake	Check the electrical connection and correct faults, if found.
	• Voltage applied to field coil too high	Check the field coil supply voltage and correct faults, if found.
	• Damaged rectifier	Check the rectifier and replace it, if necessary.
Delayed brake engagement	• Air gap too large	Check the air gap. Install a new brake, if necessary.
	• Voltage applied to field coil too high (residual voltage)	Check the field coil supply voltage and correct faults, if found.
Brake release failure	• Voltage applied to field coil after power on too low or too high	Check the field coil supply voltage for residual voltage and correct faults, if found.
	• Friction surface thermally overloaded	Install a new brake, if necessary.
	• Damaged field coil	Check the field coil resistance. Install a new brake, if necessary.
	• Armature mechanically blocked due to bonding of armature and inner ring or outer ring	Separate the armature from the inner ring or outer ring. Install a new brake, if necessary.
Delayed brake release	• Voltage applied to field coil too low	Check the field coil supply voltage and correct faults, if found.
Brake torque too low	• Air gap too large	Check the air gap. Install a new brake, if necessary.
	• Brake operating temperature too high	Reduce the brake switching work / switching power. Cool the brake, if necessary.
	• Voltage (residual voltage) applied to field coil	Check the field coil supply voltage and correct faults, if found.
	• Oily or greasy friction surfaces	Check and clean the friction surfaces. Install a new brake, if necessary.

Table 15/1: Possible faults, causes and corrective actions (list not exhaustive)

## 8. Safety

The brakes described in these Operating Instructions have been designed and built on the basis of an analysis of hazards and in accordance with the requirements of the applicable harmonised standards and technical specifications. They correspond to the state of the art and provide maximum safety. However, safety hazards can only be avoided if the user of the equipment takes adequate precautions and makes sure that the safety instructions are strictly adhered to.

The user is required to ensure that:

- the brakes are only used in accordance with their intended use (see Section 2 "Product description").
- the brakes are in perfect working order and checked at regular intervals.
- a complete and fully legible copy of these Operating Instructions is kept available at the place of use of the brakes at all times.
- start-up, maintenance and repair work is only done by authorised and suitably qualified personnel.
- such personnel are kept informed on all relevant occupational safety and environmental protection issues and familiar with these Operating Instructions and with the safety information contained herein.
- the brakes are not exposed to other strong magnetic fields.

### 8.1 Intended use

The brakes described in these Operating Instructions are intended to be assembled with machines, in particular electric motors, for use on industrial plant. Operation in potentially explosive atmospheres or locations requiring flame-proofing is not allowed. The brakes must be used in accordance with the operating requirements detailed in this manual. The rated power limits specified herein must not be exceeded.

### 8.2 General safety information

Brakes fitted to motors feature hazardous live components and rotating parts and may exhibit hot surfaces. Any work associated with the transport, connection, start-up and periodical maintenance of the brakes must be carried out by authorised and suitably qualified personnel (in accordance with VDE 0105; IEC 364). Failure to observe safety, operating and maintenance instructions may cause serious personal injury and severe damage to the equipment. Whenever special measures are required in accordance with the instructions contained herein, such measures should be agreed with the brake manufacturer before the machinery into which the brake is to be incorporated is set up. Should any queries arise with respect to torques, torque variations, installation positions, wear, wear reserve, switching work, break-in conditions, release range, ambient conditions and the like, please contact Kendrion Binder and ask for clarification before using the brake. Retrofitting or modification work to be carried out on the brake is subject to the approval from Kendrion Binder. Accident prevention regulations applying to the specific field of application of the brake must be strictly observed. The brakes described in this manual are **not** designed for use as "**safety brakes**". This means that torque reductions caused by factors beyond the user's control cannot be excluded.

#### 8.2.1 Set-up

Requirements in terms of the permitted number of switching operations per hour and the maximum switching work per switching operation specified in the technical specifications must be strictly observed during the set-up of machines and plant (inching mode). Failure to observe these instructions may irreversibly diminish the braking effect and cause malfunctions. The operating conditions at normal rating specified in these Operating Instructions refer to DIN VDE 0580. The protection type is based on EN 60529. Bear in mind that the armature may freeze to the pole faces of the excitation system if ambient temperatures fall below -5°C or if the brake remains unpowered for prolonged periods of time. In this case, special precautions must be taken after consultation with the manufacturer.

## 8.2.2 Set-up and start-up

The brakes must not be put into operation when:

- power supply cables/wires or connections are damaged.
- the coil sheath is damaged.
- other defects are suspected.

## 8.2.3 Installation

The voltage and voltage type specified on the rating plate must be strictly observed when connecting the brakes described in these Operating Instructions. Sufficient heat dissipation must be ensured when the brake is fitted to or incorporated into other equipment.

Adequate precautions must be taken to avoid overvoltage during disconnection or voltage peaks. The magnetic field of the products may cause interference outside the brake or even feedback to the brake in case of adverse installation conditions. Should you have queries concerning mounting and fitting conditions, please contact the brake manufacturer and ask for clarification.

Adequate safety measures (DIN VDE 0848, part 4; DIN 31000/VDE 1000; DIN VDE 0100, part 0420) must be taken by the brake user to avoid hazards to persons and animals or damage to equipment caused by:

- direct or indirect effects of electromagnetic fields,
- heated components,
- mobile parts.

## 8.2.4 Operation

Make sure that live components such as plug contacts or the field coil are not exposed to water. The brake cable connections must not be crushed, squeezed or exposed to mechanical loads. Make absolutely sure that the friction surfaces of the friction elements are not contaminated with grease, oil or other liquids to avoid substantial torque reduction. Bear in mind that the original torque cannot be restored even if the friction surfaces are cleaned after contact with liquids. The gradual brake wear (only with service brakes) must be taken into consideration during set-up. Due to the diverse ambient conditions in which the brakes may be used, always check that the brake is in perfect working order before start-up. Torque reductions cannot be excluded if the brake is used for applications where only minimum friction work is required. In such cases, the user should ensure that the brake occasionally performs sufficient friction work. The brakes are factory-treated with a basic corrosion inhibitor to provide protection during storage and operation in dry environments (no condensation).



### Note!

The brake must be operated at an ambient temperature of between -15°C and +120°C and a relative humidity of 75% (at 20°C ambient temperature).



### Attention!

A maximum 6g continual shock load over a lifecycle of 20,000 operating hours is permitted for the permanent-magnet single-face brake. The armature connection, hub connection and electrical connection are subject to the user's approval. Vibration loads with a maximum excursion of 1.5 mm and a maximum 6g acceleration are permitted within a frequency band of 10 to 2000 Hz.



### Note!

The brake, and more specifically the armature, is not subject to specific requirements in terms of the balance quality grade to DIN ISO 1940-1. Consequently, the required balance quality must be agreed between the manufacturer and customer in each individual case.

**Note!**

The maximum air gap  $s_{max}$  (see Table 21/1 "Technical specifications") must not be exceeded throughout the entire brake service life. (Please refer to Section 4 "Maintenance" for details.)



**Note!**

The transmissible torque  $M_4$  (see Table 21/1 "Technical specifications") is not fully reached until the break-in process has been completed (burnishing of friction surfaces; see Table 21/3 for break-in parameters). Before the brake is first used, the break-in process must be conducted by the brake user.

### 8.2.5 Maintenance and repair

Repair work must only be carried out by suitably qualified personnel (definition to IEC 364). Failure to perform repairs according to requirements may cause serious personal injury or equipment damage. Make sure that no voltage is applied to the brakes when carrying out maintenance work.

### 8.3 Warning symbols

Personal injury or equipment damage			
Symbol / Term	Warns against...		Potential risks and hazards
	Danger	imminent personal injury	fatal accidents or serious injury
	Warning	potential risk of serious personal injury	fatal accidents or serious injury
	Caution	potential risk of personal injury	minor injury
	Attention	potential risk of equipment damage	damage to the components or other equipment
Information			
Symbol / Term	Provides information on ...		
	Note	the safe use and operation of the product	

## 9. Definitions

(based on: DIN VDE 0580 July 2000, not exhaustive)

<b>Switching torque <math>M_1</math></b>	torque acting on the shaft during brake or clutch slip
<b>Rated torque <math>M_2</math></b>	switching torque specified by the manufacturer to identify the brake. The rated torque $M_2$ is the mean value of at least 3 measurements of the maximum switching torque $M_1$ after completion of the transient response.
<b>Transmissible torque <math>M_4</math></b>	highest torque that can be applied to the engaged brake or clutch without causing the brake/clutch to slip
<b>Residual torque <math>M_5</math></b>	torque transmitted by the released brake or clutch
<b>Load torque <math>M_6</math></b>	torque acting on the drive of the engaged brake or clutch; determined by the power requirement of the driven machine at a given speed
<b>Switching work <math>W</math></b>	heat generated by friction inside the brake or clutch as a result of the switching operation
<b>Maximum switching work <math>W_{max}</math></b>	maximum switching work to which the brake or clutch may be exposed
<b>Switching power <math>P</math></b>	switching work converted into heat per unit of time
<b>Maximum switching power <math>P_{max}</math></b>	maximum permitted switching work converted into heat per unit of time
<b>Coil ON time <math>t_5</math></b>	time between power on and power off
<b>Coil OFF time <math>t_6</math></b>	time between power off and power on
<b>Total cycle time <math>t_7</math></b>	coil ON time plus coil OFF time
<b>Duty cycle</b>	percentage relationship of coil ON time to total cycle time
<b>Switching operation</b>	one complete switching on and off operation
<b>Switching frequency <math>Z</math></b>	number of regular switching operations per hour
<b>Response delay during coupling <math>t_{11}</math></b>	time between power off (releasing systems) or power on (engaging systems) and beginning of torque increase
<b>Rise time <math>t_{12}</math></b>	time it takes to reach 90% of the $M_2$ rated torque from the beginning of the torque increase
<b>Coupling time <math>t_1</math></b>	response delay $t_{11}$ plus rise time $t_{12}$
<b>Response delay during disconnection <math>t_{21}</math></b>	time between power on (releasing systems) or power off (engaging systems) and beginning of torque decrease
<b>Fall time <math>t_{22}</math></b>	time it takes for the torque from the beginning of the torque decrease to fall to 10% of the $M_2$ rated torque
<b>Disconnection time <math>t_2</math></b>	response delay $t_{21}$ plus fall time $t_{22}$
<b>Slip time <math>t_3</math></b>	time from the beginning of the torque increase up to the end of the braking process (brakes) or until the synchronisation torque $M_3$ has been reached (clutches)
<b>Making time <math>t_4</math></b>	response delay $t_{11}$ plus slip time $t_3$ (braking or acceleration time)
<b>Operating condition at operating temperature</b>	condition at which the steady-state temperature is reached. The operating temperature corresponds to the overtemperature according to DIN VDE 0580 plus the ambient temperature. Unless otherwise specified, the ambient temperature is 35°C.

<b>Overtemperature <math>\Delta\vartheta_{31}</math></b>	difference between the temperature of the electromagnetic device or a part thereof and the ambient temperature
<b>Limit temperatures of coil insulating materials</b>	in accordance with DIN VDE 0580. The individual insulating materials are classified by insulation classes to DIN IEC 85.
<b>Rated voltage <math>U_N</math></b>	supply voltage specified by the manufacturer for voltage windings to identify the device or component
<b>Rated current <math>I_B</math></b>	amperage determined by the manufacturer for the specified operating conditions. Unless otherwise specified, the rated current refers to the rated voltage, 20°C winding temperature and to the rated frequency for a given operating mode of voltage windings.
<b>Rated power <math>P_N</math></b>	power value to identify the device or component
<b>Rated power at 20°C winding temperature <math>P_B</math></b>	determined from the rated current of voltage-controlled devices and components and the $R_{20}$ resistance at 20°C winding temperature

## 10. Technical specifications

Product built and tested to DIN VDE 0580

		Size					
		06	07	09	11	14	16
Transmissible torque $M_4$	[Nm]	3.2	11	22	40	80	120
Max. speed $n_{max}$	[rpm]	10000	10000	10000	10000	8000	8000
Max. switching power $P_{max}$	[kJ/h]	7	8	11	17	29	31
Max. switching work $W_{max}$ (Z=1)	[kJ]	0.35	0.4	0.55	0.85	1.45	1.55
Rated power $P_N$	[W]	12	16	18	24	35	37
Coupling time $t_1$	[ms]	19	20	25	25	53	80
Disconnection time $t_2$	[ms]	29	29	50	73	97	150
Moment of inertia of armature (with flange hub) J	[kgcm <sup>2</sup> ]	0.38	1.06	3.6	9.5	31.8	57.5
Weight (without flange hub) m	[kg]	0.3	0.6	1.1	1.4	4.1	6
Rated air gap $s^{+0.1}$	[mm]	0.2	0.3	0.3	0.3	0.3	0.3
Max. air gap $s_{max}$	[mm]	0.5	0.65	0.7	0.8	0.8	0.8
Duty cycle [%]		100					
Standard rated voltage [VDC]		24, 205					
Insulation class		F					
Pollution degree		2					
Protection		IP00					
Brake type		holding brake with emergency stop function					

Table 21/1: Technical specifications

		Size											
		06		07		09		11		14		16	
Switching operations (emergency stops) Z	[h <sup>-1</sup> ]	2	4	2	4	2	4	2	4	2	4	2	4
Max. switching work $W_{max}$	[J]	350	345	400	395	550	540	850	840	1450	1440	1550	1540

Table 21/2: Max. switching work  $W_{max}$  as a function of the number of switching operations (emergency stops) per hour Z (values based on  $n = 3000$  rpm)

		Size					
		06	07	09	11	14	16
Speed n	[rpm]	250	200	100	100	100	100
Coil ON time $t_5$	[s]	0.2	0.1	0.15	0.23	0.4	0.4
Coil OFF time $t_6$	[s]	0.2	0.1	0.15	0.25	0.4	0.45
Duty cycle $t_{tot}$	[min]	approx. 5	approx. 2	approx. 3	approx. 4	approx. 4	approx. 5

Table 21/3: Break-in process parameters for permanent-magnet single-face brakes

### Explanations on the technical specifications:

$W_{max}$  (maximum switching work) is the switching work that must not be exceeded during braking operations at max. 3000 rpm. Braking operations at >3000 rpm substantially reduce the maximum permitted switching work per switching operation. Such operation is only allowed after prior consultation with the manufacturer. The maximum switching power  $P_{max}$  is the switching work  $W$  that can be converted by the brake per hour. The permitted number of switching operations (emergency stops)  $Z$  per hour and the resulting maximum permitted switching work  $W_{max}$  are specified in Table 21/2. When the brake is used for other applications (e.g. as service brake) the values given in Fig. 22/1 apply. The  $P_{max}$  and  $W_{max}$  values are approximate values; they apply to applications where the brake is used without additional cooling and for emergency stops. The specified times apply to the following conditions: DC side brake switching, operating temperature, rated voltage, and rated air gap. These values are mean values that are subject to variation. In case of AC side brake switching, the coupling time  $t_1$  is substantially longer. The specified transmissible torques  $M_4$  characterise the torque level of the brakes. Depending on the application the brake is used for, the switching torque  $M_1$  and the effective transmissible torque  $M_4$  may differ from the specified  $M_4$  values. The switching torque  $M_1$  depends on the speed (rpm). If the friction surfaces are contaminated with oil or grease the transmissible torque  $M_4$  and the switching torque  $M_1$  may drop. The technical specifications apply after the break-in process has been completed (see Table 21/3).

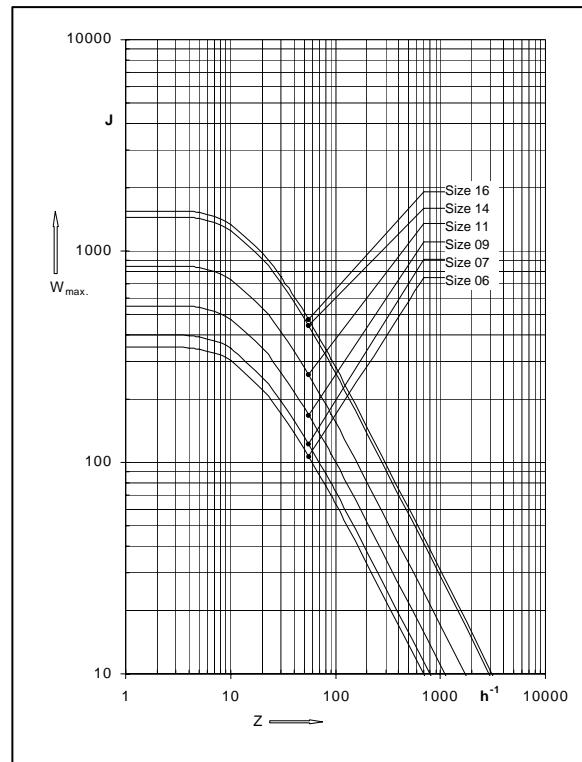

Fig. 22/1: Max. switching work  $W_{max}$  per switching operation as a function of the number of switching operations per hour  $Z$  (values based on  $n=3000$  rpm)

The required operating conditions specified in **DIN VDE 0580** and the information provided in the PM LINE specification sheet, layout drawing and **Technical Customer Information (TCI) 86 611..H00** must be observed during operation of the permanent-magnet single-face brake!

### Specifications subject to change without notice!

## 11. Authorised repair shops for maintenance work

**Steinlen**  
**Elektromaschinenbau GmbH**  
 Ehlbeek 21  
 30938 Burgwedel  
 Germany  
 Tel. +49 (0)5139 8070-0  
 Fax +49 (0)5139 8070-60

**Elmatec**  
 Straub + Müller GmbH  
 Benzstr. 2  
 78080 Dauchingen  
 Germany  
 Tel. +49 (0)7720 957171  
 Fax +49 (0)7720 957173

**Klebs + Hartmann**  
 August-Heller-Str. 1-3  
 67065 Ludwigshafen-Mundenheim  
 Germany  
 Tel. +49 (0)621 57900-0  
 Fax +49 (0)621 57900-95



INDUSTRIAL DRIVE SYSTEMS

Kendrion Binder Magnete GmbH  
Industrial Drive Systems  
Mönchweilerstr. 1  
78048 Villingen-Schwenningen  
Germany

Tel. +49 (0)7721 877-1417  
Fax +49 (0)7721 877-1462  
[www.kendrion-electromagnetic.com](http://www.kendrion-electromagnetic.com)  
[sales-ids@kendrion.com](mailto:sales-ids@kendrion.com)